

ATD 2S A 4 Y 7

Through hollow shaft $\varnothing 10$ to $\varnothing 14$ mm

Optical multiturn encoders max. 24 bit MT

Overview

- Encoder multiturn / SSI
- Optical sensing singleturn, magnetical sensing multiturn
- Resolution: max. multiturn 24 bit
- Through hollow shaft $\varnothing 10 \dots 14$ mm
- Self-diagnostic
- Electronic zero point adjustment
- Flange connector radial

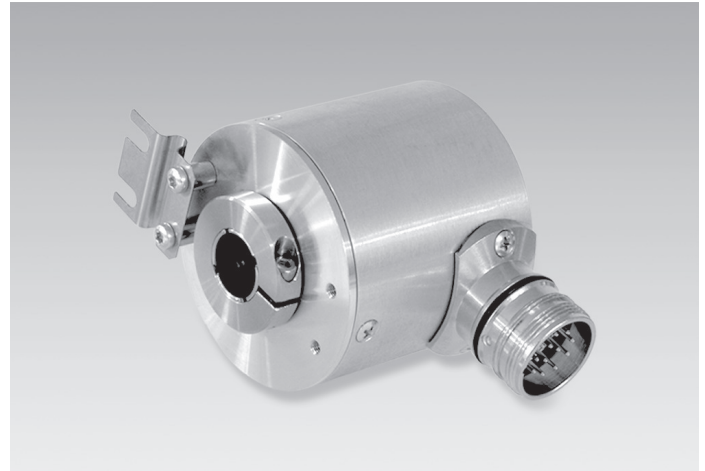

Technical data

Technical data - electrical ratings

Voltage supply	10...30 VDC
Reverse polarity protection	Yes
Consumption w/o load	≤ 70 mA (24 VDC)
Interface	SSI SSI + incremental
Function	Multiturn
Steps per revolution	$\leq 16384 / 14$ bit
Number of revolutions	$\leq 16777216 / 24$ bit
Sensing method	Optical (singleturn) Magnetical (multiturn)
Code	Gray or binary
Code sequence	CW: ascending values with clockwise sense of rotation; looking at mounting surface CW/CCW be selectable by input V/R
Inputs	SSI clock Zero setting input
Output stages	SSI data: linedriver RS485 Diagnostic output: error
Incremental output	2048 pulses A90°B + inv. HTL (optional) 2048 pulses A90°B + inv. TTL (optional) 2048 sinewaves A, B, sine 1 Vpp (optional)

Technical data - electrical ratings

Interference immunity	DIN EN 61000-6-2
Emitted interference	DIN EN 61000-6-3

Technical data - mechanical design

Size (flange)	$\varnothing 58$ mm
Shaft type	$\varnothing 10$ mm (through hollow shaft) $\varnothing 12$ mm (through hollow shaft) $\varnothing 14$ mm (through hollow shaft)
Protection DIN EN 60529	IP 65
Operating speed	≤ 8000 rpm (mechanical) ≤ 8000 rpm (electric)
Starting torque	$\leq 0,02$ Nm (+20 °C)
Material	Housing: aluminium Shaft: stainless steel
Operating temperature	-20...+85 °C
Relative humidity	90 % non-condensing
Resistance	DIN EN 60068-2-6 Vibration 10 g, 55-2000 Hz DIN EN 60068-2-27 Shock 30 g, 11 ms
Weight approx.	325 g
Connection	Connector M23 type 2, 12-pin Connector M23 type 2, 17-pin
Mounting kit	002

Optional

- HTL or TTL incremental signals
- Sine signals

ATD 2S A 4 Y 7

Through hollow shaft $\varnothing 10$ to $\varnothing 14$ mm

Optical multiturn encoders max. 24 bit MT

Terminal assignment

ATD 2S A 4 Y 7

Connector	Assignment
Pin 1	clock-
Pin 2	clock+
Pin 3	data+
Pin 4	data-
Pin 5	–
Pin 6	–
Pin 7	reset
Pin 8	V/\bar{R}
Pin 9	– (do not use)
Pin 10	error
Pin 11	UB
Pin 12	GND

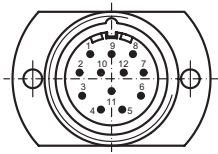

ATD 2S A 4 Y 7 with incremental output signals

Connector	Assignment
Pin 1	clock-
Pin 2	clock+
Pin 3	data+
Pin 4	data-
Pin 5	–
Pin 6	–
Pin 7	reset
Pin 8	V/\bar{R}
Pin 9	– (do not use)
Pin 10	error
Pin 11	UB
Pin 12	GND
Pin 13	–
Pin 14	track A+
Pin 15	track A-
Pin 16	track B+
Pin 17	track B-

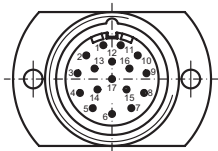

Terminal significance

UB	Encoder supply voltage.
GND	Encoder ground connection relating to UB.
Data+	Positive, serial data output of differential linedriver.
Data-	Negative, serial data output of differential linedriver.
Clock+	Positive SSI clock input. Clock+ together with clock- forms a current loop. A current of approx. 7 mA towards clock+ input means logic 1 in positive logic.
Clock-	Negative SSI clock input. Clock- together with clock+ forms a current loop. A current of approx. 7 mA towards clock- input means logic 0 in positive logic.
Reset	Reset input for setting zero position value at any desired point within the entire resolution. The resetting process is triggered by apply of UB.
V/\bar{R}	V/\bar{R} counting direction input. This input is standard on High. V/\bar{R} means increasing values with clockwise shaft rotation when looking at the mounting side (CW). V/\bar{R} -Low means decreasing values with clockwise shaft rotation when looking at the mounting side (CCW).
Error	Diagnostic output (Open Collector with internal 10 k Ω pullup-resistor). The output is high-active, that means if no fault submitted, the output is to GND interconnected.

Trigger level

SSI	Circuit
SSI-Clock	Optocoupler
SSI-Data	Linedriver RS485

Control input	Input circuit
Input level High	$\geq 0,7$ UB
Input level Low	$\leq 0,3$ UB
Input resistance	10 k Ω

Diagnostic outputs	Output circuit
Output level	Open Collector with internal 10 k Ω PullUp-resistance

Incremental outputs	HTL - Line Driver short-circuit proof
Output level High	$\geq UB - 3$ V
Output level Low	$\leq 0,5$ V
Load	≤ 30 mA

Incremental outputs	TTL - Line Driver short-circuit proof
Output level High	$\geq 2,4$ V
Output level Low	$\leq 0,5$ V
Load	≤ 30 mA

Outputs	Sine / Cosine
Output amplitude	1 V_{PP} at $Z_0 = 120 \Omega$

ATD 2S A 4 Y 7

Through hollow shaft $\varnothing 10$ to $\varnothing 14$ mm

Optical multiturn encoders max. 24 bit MT

Data transfer

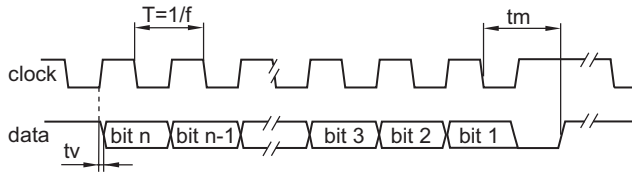

Clock frequency f	80...1000 kHz
Duty cycle of T	40...60 %
Delay time t_v	150 ns
Monoflop time t_m	$20 \mu s + T/2$
Clock interval t_p	$26 \mu s$

ATD 2S A 4 Y 7

Through hollow shaft $\varnothing 10$ to $\varnothing 14$ mm

Optical multiturn encoders max. 24 bit MT

Dimensions

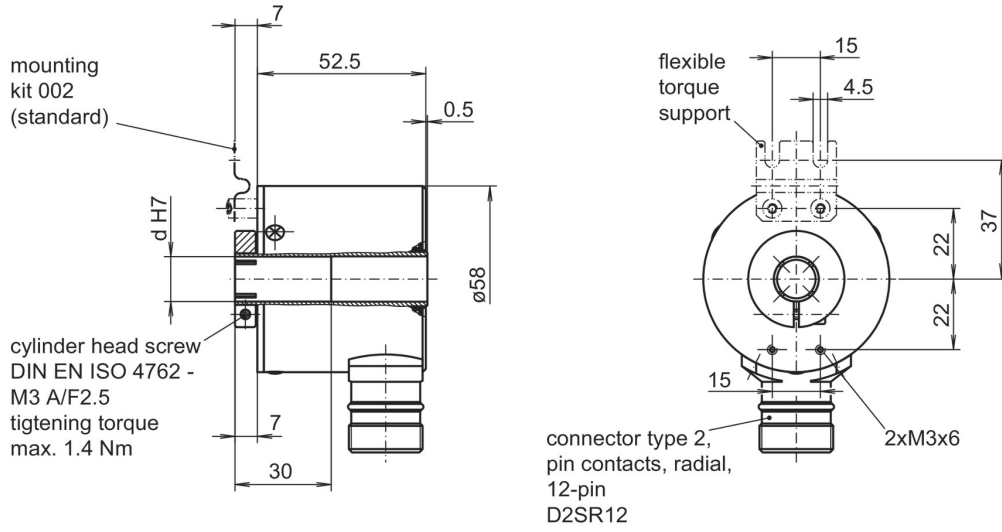

ATD 2S A 4 Y 7

 Through hollow shaft $\varnothing 10$ to $\varnothing 14$ mm

Optical multiturn encoders max. 24 bit MT

Ordering reference

	ATD 2S A 4 Y 7	####	SS	####	#####	S	##	IP65	002
Product	ATD 2S A 4 Y 7								
Resolution									
9/12 bit single-/multiturn		9/12							
10/12 bit single-/multiturn		10/12							
11/12 bit single-/multiturn		11/12							
12/12 bit single-/multiturn		12/12							
13/12 bit single-/multiturn		13/12							
Interface									
Serial SSI			SS						
Output signals									
Gray code					GR				
Binary code					BI				
Connection									
Flange connector type 2, pin contacts, radial, 12-pin						D2SR12			
Flange connector type 2, pin contacts, radial, 17-pin (SSI + incremental signals resp. SSI + sine signals)						D2SR17			
Operating temperature							S		
-20...+85 °C									
Through hollow shaft									
$\varnothing 10$ mm							10		
$\varnothing 12$ mm							12		
$\varnothing 14$ mm							14		
Protection									
IP 65								IP65	
Mounting kit									
Mounting kit 002									002

Other resolutions on request.

Accessories

Connectors and cables

11011122	Connector S2BG12, 1 m cable (ATD)
11071749	Connector S2BG12, 5 m cable (ATD)
11070261	Connector S2BG17, 1 m cable (ATD)
11070262	Connector S2BG17, 2 m cable (ATD)
11070263	Connector S2BG17, 5 m cable (ATD)