

ATD 2A A 4 Y 7

 Through hollow shaft $\varnothing 10$ to $\varnothing 14$ mm

Optical single- or multiturn encoders with analog output

Overview

- Encoder multiturn / analog output
- Voltage output or current output
- Control inputs reset and rotating direction
- Optical sensing singleturn, magnetical sensing multiturn
- Self-diagnostic
- Total resolution: 16 bit
- Factory-set adjustable angle (0° - 360° resp. up to $16 \times 360^\circ$)
- Flange connector radial

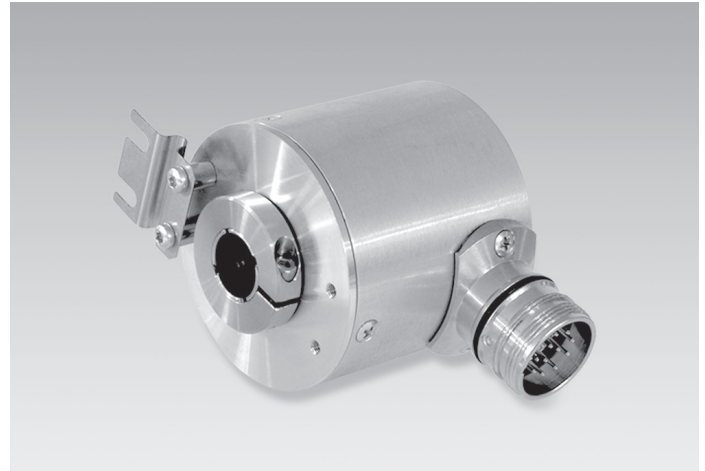

Technical data

Technical data - electrical ratings

Voltage supply	+UB= 12...30 VDC (IS-/US-version)
Reverse polarity protection	Yes
Consumption w/o load	≤ 50 mA (24 VDC)
Interface	Analog (4...20 mA or 0...10 V)
Load resistor	≥ 1 k Ω (recommended 10 k Ω) / voltage output ≤ 500 Ω (recommended 470 Ω) / current output
Function	Singleturn Multiturn
Measuring range	90° , 180° , 360° 2, 4, 8, 16 revolutions
Resolution	16 bit
Steps per revolution	16384 / 14 bit
Number of revolutions	16 / 4 bit
Sensing method	Optical (singleturn) Magnetical (multiturn)
Updating values	≤ 130 μ s
Code sequence	CW: ascending values with clockwise sense of rotation; looking at mounting surface
Output stages	Voltage output (short-circuit proof) Current output (short-circuit proof)

Technical data - electrical ratings

Interference immunity	DIN EN 61000-6-2
Emitted interference	DIN EN 61000-6-3
Technical data - mechanical design	
Size (flange)	$\varnothing 58$ mm
Shaft type	$\varnothing 10$ mm (through hollow shaft) $\varnothing 12$ mm (through hollow shaft) $\varnothing 14$ mm (through hollow shaft)
Protection DIN EN 60529	IP 65
Operating speed	≤ 8000 rpm (mechanical) ≤ 6000 rpm (electric)
Starting torque	$\leq 0,02$ Nm ($+20^\circ$ C)
Material	Housing: aluminium Shaft: stainless steel
Operating temperature	$-20...+85^\circ$ C
Relative humidity	90 % non-condensing
Resistance	DIN EN 60068-2-6 Vibration 10 g, 55-2000 Hz DIN EN 60068-2-27 Shock 30 g, 11 ms
Weight approx.	325 g
Connection	Connector M23 type 2, 12-pin
Mounting kit	002

ATD 2A A 4 Y 7

Through hollow shaft $\varnothing 10$ to $\varnothing 14$ mm

Optical single- or multiturn encoders with analog output

Terminal assignment

ATD 2A A 4 Y 7

Connector	Assignment
Pin 1	NC
Pin 2	NC
Pin 3	NC
Pin 4	GND _{OUT}
Pin 5	U _{OUT} resp. I _{OUT}
Pin 6	NC
Pin 7	reset
Pin 8	V \bar{R}
Pin 9	error
Pin 10	GND
Pin 11	NC
Pin 12	+UB

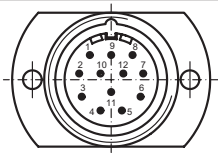

Terminal significance

+UB	Encoder supply voltage.
GND	Encoder ground connection relating to UB.
U _{OUT}	Voltage output increasing at clockwise rotation when looking at the mounting side.
I _{OUT}	Current output increasing at clockwise rotation when looking at the mounting side.
GND _{OUT}	Reference voltage for analogue output.
Reset	Reset input for setting zero position value at any desired point within the entire resolution. The resetting process is triggered by apply of UB.
V \bar{R}	V \bar{R} counting direction input. This input is standard on High. V \bar{R} means increasing values with clockwise shaft rotation when looking at the mounting side. V \bar{R} -Low means decreasing values with clockwise shaft rotation when looking at the mounting side.
error	Diagnostic output (Open Collector with internal 10 k Ω pullup-resistor). The output is low-active, that means if no fault submitted, the output is +UB.

Output signals

Unipolar Output (IS-/US-version)

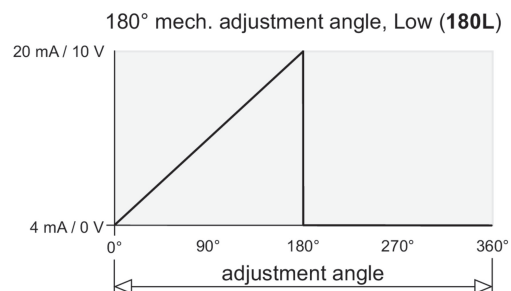
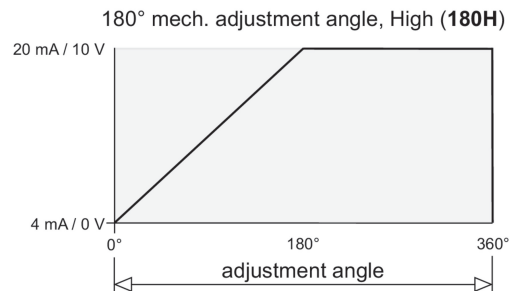
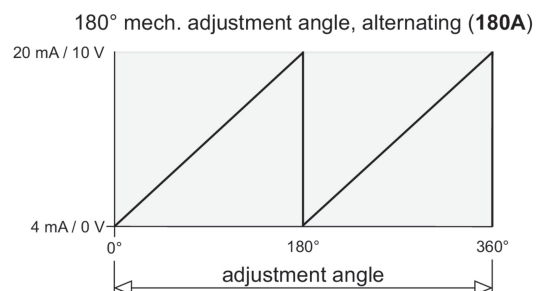
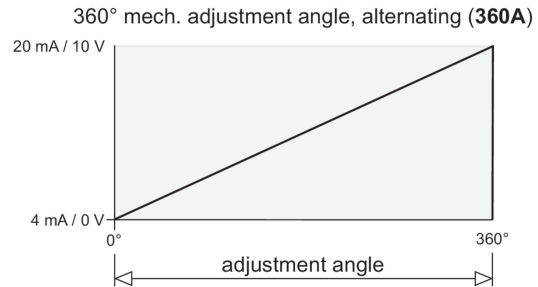

Output signals

Unipolar Output (IS-/US-version)

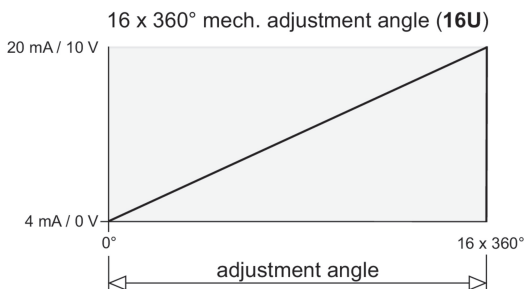
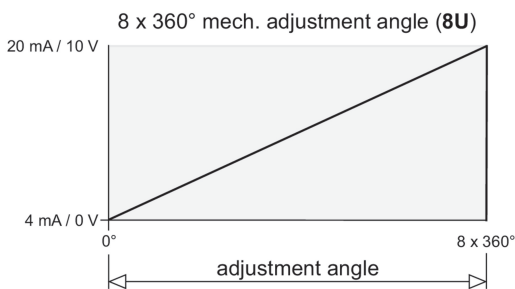
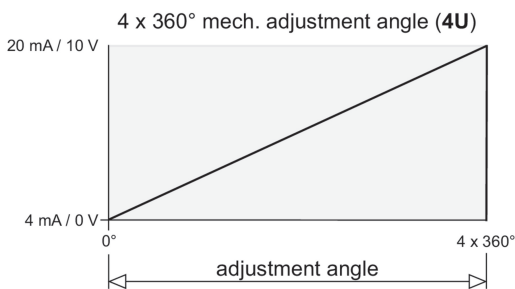
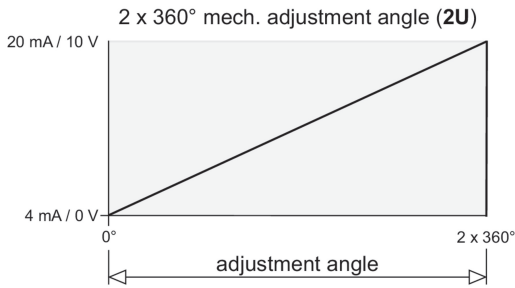

Trigger level

Control input	Input circuit
Input level High	$\geq 0,7$ UB
Input level Low	$\leq 0,3$ UB
Input resistance	10 k Ω

Diagnostic outputs	Output circuit
Output level	Open Collector with internal 10 k Ω PullUp-resistance

ATD 2A A 4 Y 7

Through hollow shaft $\varnothing 10$ to $\varnothing 14$ mm

Optical single- or multiturn encoders with analog output

Dimensions

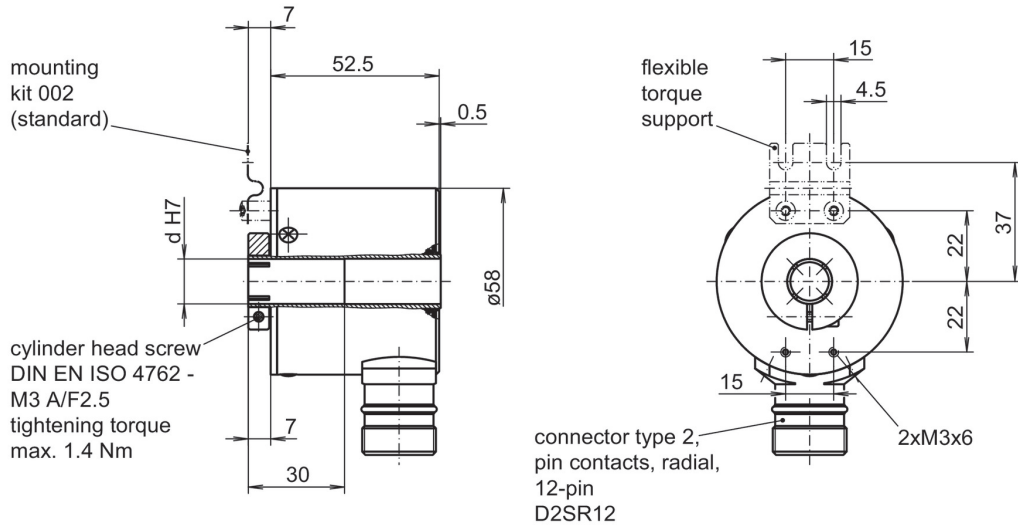

ATD 2A A 4 Y 7

 Through hollow shaft $\varnothing 10$ to $\varnothing 14$ mm

Optical single- or multiturn encoders with analog output

Ordering reference

	ATD 2A A 4 Y 7	####	##	D2SR12	S	##	IP65	002
Product	ATD 2A A 4 Y 7							
Resolution								
360° mech. adjustment angle, alternating (singleturn)		360A						
180° mech. adjustment angle, alternating (singleturn)		180A						
180° mech. adjustment angle, High (singleturn)		180H						
180° mech. adjustment angle, Low (singleturn)		180L						
2 x 360° mech. adjustment angle (multiturn)		2U						
4 x 360° mech. adjustment angle (multiturn)		4U						
8 x 360° mech. adjustment angle (multiturn)		8U						
16 x 360° mech. adjustment angle (multiturn)		16U						
Interface								
Current output, standard, 4...20 mA, $V_{in} = 12...30$ VDC					IS			
Voltage output, standard, 0...+10 VDC, $V_{in} = 12...30$ VDC					US			
Connection								
Flange connector type 2, pin contacts, radial, 12-pin				D2SR12				
Operating temperature								
-20...+85 °C					S			
Through hollow shaft								
$\varnothing 10$ mm							10	
$\varnothing 12$ mm							12	
$\varnothing 14$ mm							14	
Protection								
IP 65							IP65	
Mounting kit								
Mounting kit 002								002

Other adjustment on request.